



VOX SERIES

Exterior LED Surface Mounted Up/Down Wall Lights



VOX1



VOX2



VOX3

Exterior Lighting

Product Features

- Exterior surface mounted up/down LED wall lights
- Input voltage: 100~240V AC 50/60Hz
- Output voltage: 5.5~30V
- Nominal current: 350mA
- Material: aluminium
- Bracket: aluminium
- LED chips: 32pcs SMD2835 LED chips
- Wattage: 9W
- Power factor: ≥ 0.5
- Ambient temp: -20 to $+45^{\circ}\text{C}$
- Not suitable for dimming
- Suitable for 2-way switching
- Suitable for use with PIR & Microwave sensors

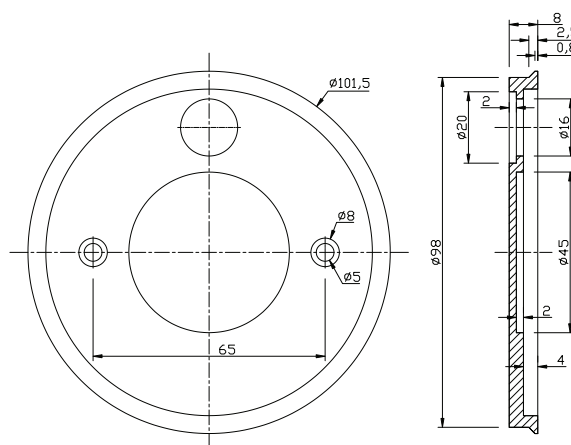
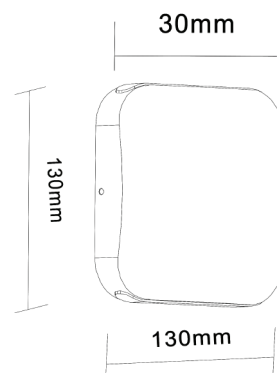

Back plate dimensions

30,000hr
Lifetime

120°
Beam Angle

CRI80

IP54
Rated

2YEAR
Replacement Warranty

PART NO.	DESCRIPTION	KELVIN (K)	LUMENS (LM)	WATT (W)	CRI	WIDTH (MM)	DEPTH (MM)	WEIGHT (KG)	BOX (CM)	CARTON QTY
VOX1	WALL LED S/M BLK SQ Up/Down 3000K	3000	808	9	80	130	30	0.75	15x14x4	24
VOX2	WALL LED S/M Sand WH SQ Up/Down 3000K	3000	808	9	80	130	30	0.75	15x14x4	24
VOX3	WALL LED S/M Polished Alu SQ Up/Down 3000K	3000	737	9	80	130	30	0.75	15x14x4	24